



SOLUZIONI
PER IL POMPAGGIO
DEI FLUIDI

SOLUTIONS
FOR FLUIDS
PUMPING

Via Lazzari 1, 40057 QUARTO INFERIORE (BO) ITALY
Tel. +39.051.767605 - Fax +39.051.768622



POMPA - PUMP SB400

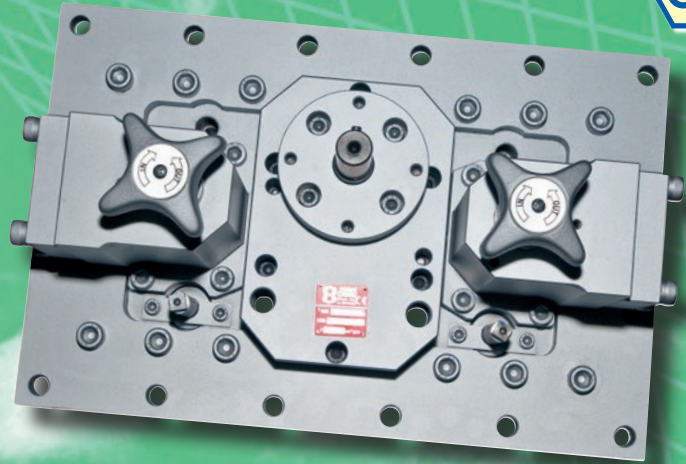

AUTOADESCANTI AD INGRANAGGI DA FLANGIARE SULLE CISTERNE

Cilindrata: 270 cm³/giro

Portata: 250 l/min. a 950 giri/min.
380 l/min. a 1.450 giri/min.

Peso: 85 kg.

- Corpo pompa completamente immerso entro la cisterna.
- Camicie di riscaldamento che avvolgono completamente la pompa (non una semplice calotta riscaldata) per ridurre i tempi di partenza da freddo.
- Massima facilità di manutenzione, gli ingranaggi possono essere smontati dall'esterno, senza svuotare la cisterna.

SELF PRIMING GEAR PUMP TO BE FLANGED ON TANKS

Displacement: 16.5 cu.in./rev.

Delivery: 68.0 g.p.m. at 950 r.p.m.
103 g.p.m. at 1450 r.p.m.

Weight: 187 lb.

- The pump body is fully immersed inside the tank.
- Heating jackets fully enveloping the pump (not only a bottom heating cap) to reduce warm-up time.
- Very easy maintenance: pumping gears can be removed externally without emptying the tank

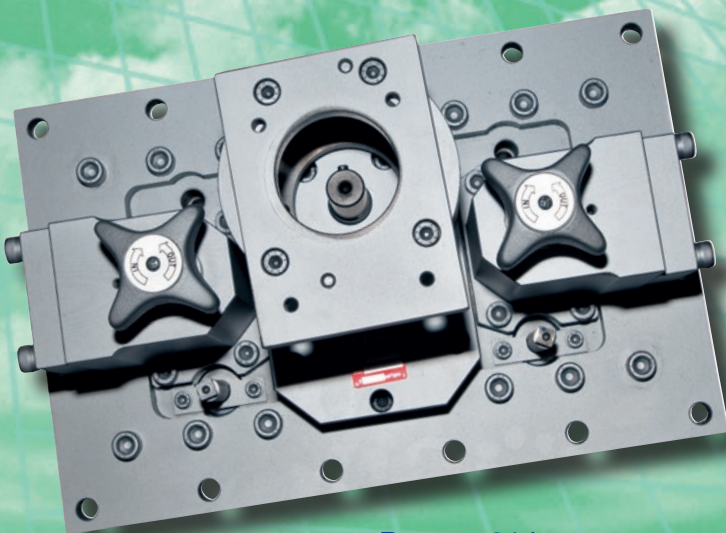

Peso 91 kg.

Weight 200 lb.

- Pratico sistema per il montaggio del motore adattato alle esigenze dimensionali del cliente.
- Very easy system for placing the motors adapted to customer geometric specifications.
- Valvole di by-pass incorporate.
- By-pass valves incorporated.
- Funzionamento completamente simmetrico, con possibilità di mandare e di aspirare sia dall'interno che dall'esterno.
- Fully symmetrical running: suction and delivery may be chosen both from inside the tank, or from outside.

giri/min r.p.m.	Portate nominali Nominal Flow		
	m ³ /h	l/min	g.p.m.
100	1,62	27,0	7.16
200	3,24	54,0	14.3
300	4,86	81,0	21.5
400	6,48	108	28.7
500	8,10	135	35.8
600	9,72	162	43.0
700	11,3	189	50.1
800	13,0	216	57.3
900	14,6	243	64.5
1000	16,2	270	71.6
1100	17,8	297	78.8
1200	19,4	324	86.0
1300	21,0	351	93.1
1400	22,7	378	100
1500	24,3	405	107

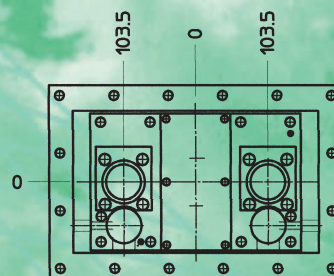
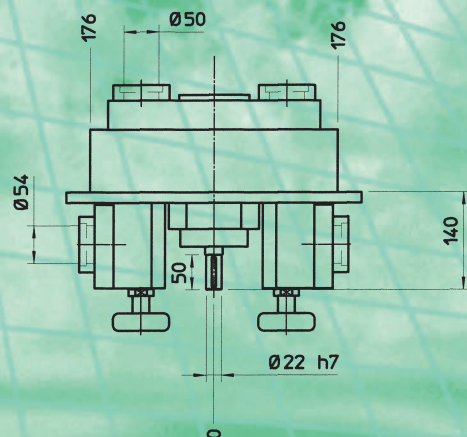
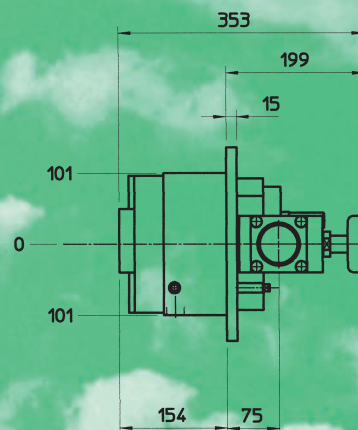
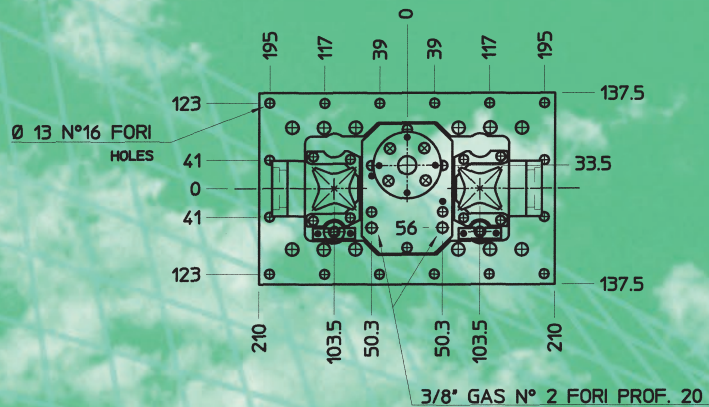
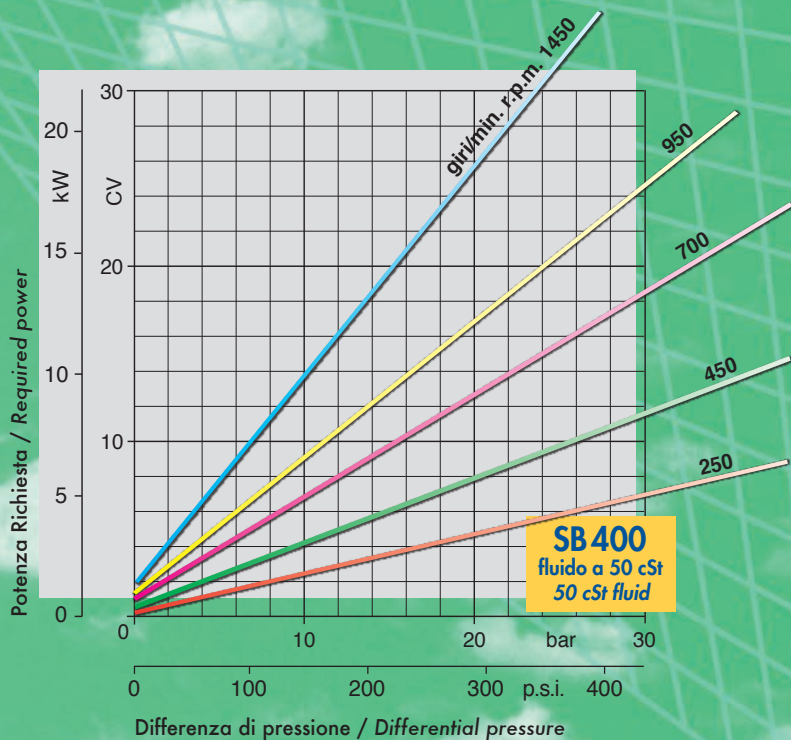

LE DIMENSIONI E I PESI NON SONO IMPEGNATIVI
DIMENSIONS AND WEIGHTS ARE NOT MANDATORY